

# Exhibit B

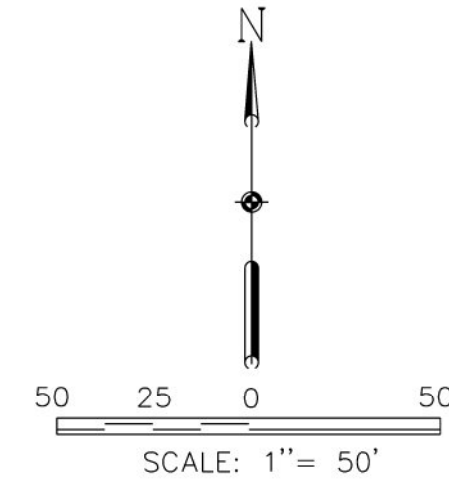

**FLOODPLAIN NOTES**

- PROPOSED SITE IS LOCATED ON FLOODPLAIN ZONE AE WITH A BASE FLOOD ELEVATION OF 14 FEET AND 500-YEAR FLOODPLAIN OF 15.9 FEET AS SHOWN ON FEMA PANEL 48167C0235G EFFECTIVE DATE 8/14/2019.
- BATTERY PADS ARE AT ELEVATION 16.3 FEET (3" ABOVE 500-YEAR FLOODPLAIN)
- PROPOSED BATTERY SITE IS RAISED TO ELEVATION 13.0 FEET (2 FEET ABOVE GROUND ELEVATION OF 11.0 FEET)
- BATTERY PADS ARE ON PILING FOUNDATION (3.3 FEET ABOVE RAISED BATTERY SITE)

**PLANT LIST TABLE**

Symbol	Size Tall	Quantity	Common Name	Botanical Name	Type	Features
●	15 ft	28	Eastern White Pine	Pinus Strobus	Evergreen Tree	Fast-Growing - Full Sun to Partial Sun - Green Leaves
⊕	30 ft	28	Black Oak	Quercus Velutina	Oak	Full Sun - Large Size - Average Draining Soil

**ALTA TABLE "A" ITEMS:**

- ALL MONUMENTS SET OR FOUND AS SHOWN ON THE SURVEY.
- ADDRESS: NO ADDRESS FOUND, FRONTAGE IS CAROLINE STREET
- THE SUBJECT TRACT LIES IN ZONE AE (ELEV. 14) FEMA FIRM MAP NO. 48167C0235G, EFFECTIVE DATE: 8/14/2019.
- THE GROSS LAND AREA OF THE SUBJECT TRACT IS 5.568 ACRES (242,544 SQUARE FEET)
- VERTICAL INFORMATION SHOWN ON SURVEY.
- (a)(b) NO ZONING REPORT OR LETTER WAS PROVIDED TO THE SURVEYOR.
- (c), 7(b)(1) & 7(c) THERE ARE NO EXISTING BUILDINGS ON THE SITE AT THE TIME OF SURVEY AS SHOWN.
- SUBSTANTIAL FEATURES OBSERVED IN THE PROCESS OF CONDUCTING FIELDWORK ARE INCLUDED ON THE SURVEY.
- (c) PLANS OF UNDERGROUND UTILITIES HAVE YET TO BE PROVIDED TO THE SURVEYOR AT TIME OF SURVEY.
- THE NAMES OF ADJOINING OWNERS ACCORDING TO CURRENT TAX RECORDS ARE INCLUDED ON THE SURVEY. IF NO DATA EXISTS ON THE GALVESTON COUNTY APPRAISAL DISTRICT, THIS IS STATED ON THE SURVEY. THE LAST KNOWN DEED FOR THE SITE SHOWN IN RECORDS HAS BEEN PROVIDED.
- THERE WAS A SMALL AREA OF SPOILS/DIRT NOTED WHICH WAS THERE AT THE TIME OF THE SURVEY.
- BOWMAN HAS PROFESSIONAL LIABILITY INSURANCE AND WILL PROVIDE STELLA ENERGY SOLUTIONS A CERTIFICATE OF INSURANCE.

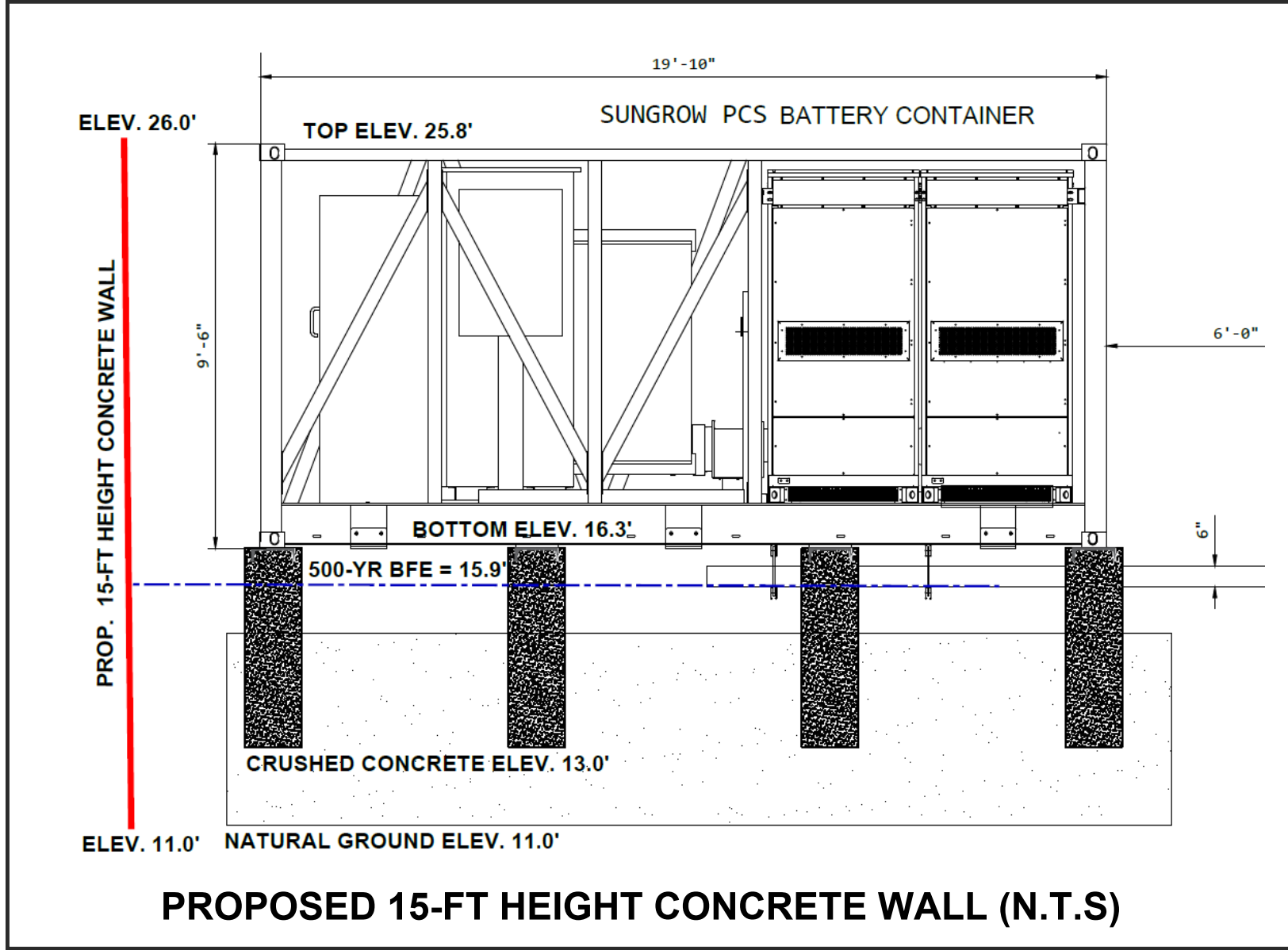
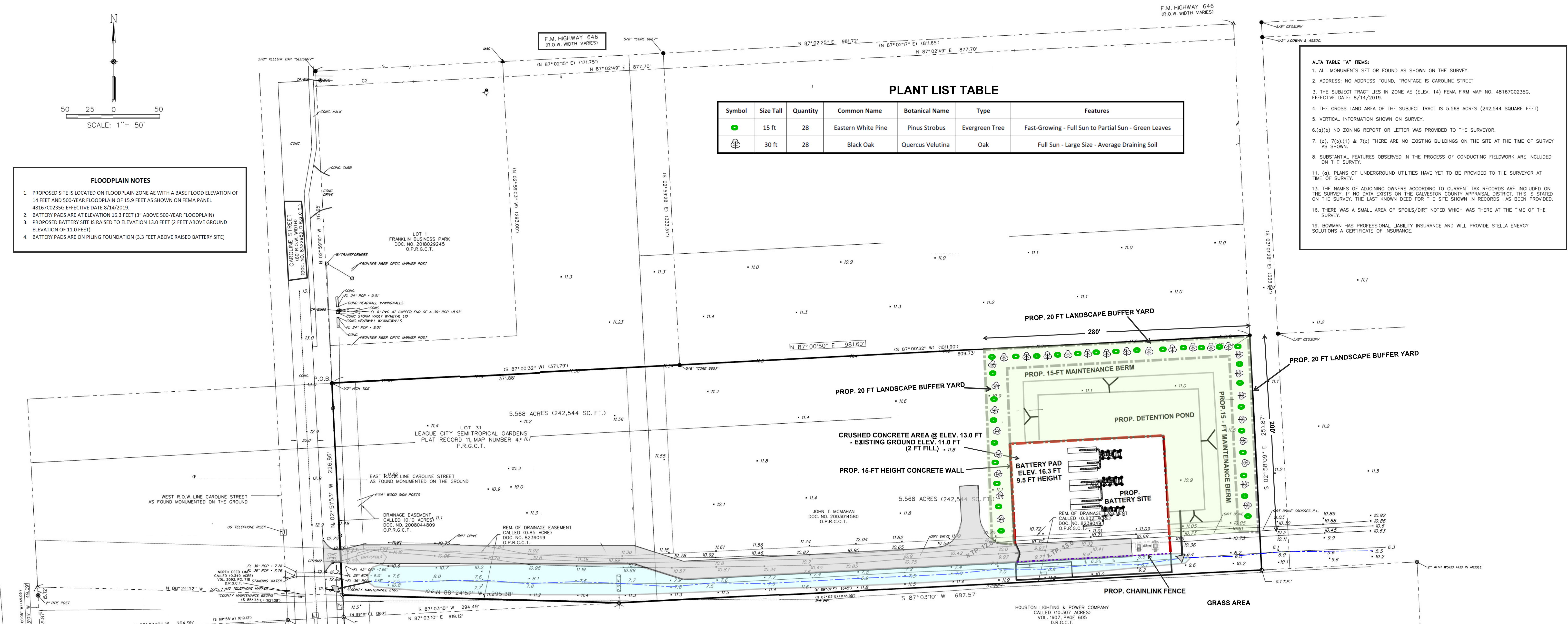

**LANDSCAPING NOTES**

- TRACT AREA = 5.568 AC.
- DEVELOPMENT (DISTURBED) AREA = 1.84 AC. (CONCRETE ACCESS ROAD/CRUSHED CONCRETE BATTERY AREA/DETENTION POND)
- MINIMUM 15% DEVELOPMENT AREA TO BE LANDSCAPED
- REQUIRED MINIMUM LANDSCAPED AREA = 0.28 AC.
- PROVIDED LANDSCAPED AREA = 20 FT X 680 FT = 13,600 SQ.FT = 0.31 AC. - GRASS (GROUND COVER) AND TREES
- EIGHT TREES PER 100 LINEAR FEET IS PROVIDED WITH HALF BEING EVERGREEN TREES AND HALF BEING OAK.
- PER PERIMETER LENGTH OF 680 FEET, 28 EVERGREEN TREES (EASTERN WHITE PINE) AND 28 BLACK OAKS ARE PROVIDED.
- A CONTINUOUS HEDGE CONSISTING OF SHRUBS THAT NOT LESS THAN 3 FEET OR MORE THAN 4 FEET IN HEIGHT AND PLANTED IN 3-5 GALLON CONTAINER STOCKS UPON INSTALLATION. HEDGES SHOULD BE PLANTED 2-3 FEET APART.
- ALL TREES WILL BE MAINTAINED IN A LIVING AND GROWING CONDITION BY LANDSCAPE CONTRACTOR
- LANDSCAPING MAINTENANCE SHALL COMPLY WITH SECTION 4.20 OF THE LEAGUE CITY UNIFIED DEVELOPMENT CODE (UDC).
- A MINIMUM OF 4 INCHES OF TOPSOIL IS PLACED ON ALL DISTURBED AREAS. SEED WITH BERMUDA TURF GRASS. HYDROMULCH OR SOD OR SEED IF NEEDED.

DESIGNED	DN
DRAWN	SSB
CHECKED	
DATE	

NO.	DATE	DESCRIPTION	APPROVED
1	02/13/24	Issued for Construction	

REVISIONS

9119 Highway 6, Suite 230 #233  
 Missouri City, Texas 77459  
 Phone: (979)264-3510  
 Firm Registration Number: F-13495

The seal appearing on this document was authorized by  
**DONG H. NGUYEN**  
 P.E. 93048  
 Date: February 13, 2024

**OWNER:**  
**STELLA ENERGY SOLUTIONS, LLC.**  
 9595 SIX PINES DR., SUITE 8210  
 THE WOODLANDS, TX 77380

PLAN: \_\_\_\_\_  
 PROFILE: \_\_\_\_\_  
 HORIZONTAL: \_\_\_\_\_  
 VERTICAL: \_\_\_\_\_

**PROPOSED**  
**HIDDEN LAKES BESS**  
**FM 646 AND CAROLINE STREET**  
**LEAGUE CITY, TX 77573**

**LANDSCAPE PLAN**  
 C-6

# Exhibit B



# Exhibit B

